

DPP - Daily Practice Problems

Name :

Date :

Start Time :

End Time :

PHYSICS

36

SYLLABUS : CURRENT ELECTRICITY – 1 (Electric Current, drift velocity, Ohm's law, Electrical resistance, Resistances of different materials, V-I characteristics of Ohm and non-ohmic conductors, electrical energy and power, Electrical resistivity, Colour code of resistors, Temperature dependence of resistance)

Max. Marks : 92

Time : 60 min.

GENERAL INSTRUCTIONS

- The Daily Practice Problem Sheet contains 23 MCQ's. For each question only one option is correct. Darken the correct circle/ bubble in the Response Grid provided on each page.
- You have to evaluate your Response Grids yourself with the help of solution booklet.
- Each correct answer will get you 4 marks and 1 mark shall be deducted for each incorrect answer. No mark will be given/ deducted if no bubble is filled. Keep a timer in front of you and stop immediately at the end of 60 min.
- The sheet follows a particular syllabus. Do not attempt the sheet before you have completed your preparation for that syllabus. Refer syllabus sheet in the starting of the book for the syllabus of all the DPP sheets.
- After completing the sheet check your answers with the solution booklet and complete the Result Grid. Finally spend time to analyse your performance and revise the areas which emerge out as weak in your evaluation.

DIRECTIONS (Q.1-Q.14) : There are 14 multiple choice questions. Each question has 4 choices (a), (b), (c) and (d), out of which **ONLY ONE** choice is correct.

Q.1 In the following fig. the ratio of current in 3Ω and 1Ω resistances is–

- (a) $1/3$
 (b) $2/3$
 (c) 1
 (d) 2

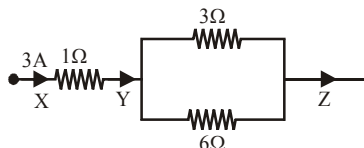

Q.2 The resultant resistance between the points A and B in the following fig. will be –

- (a) $4\ \Omega$
 (b) $8\ \Omega$
 (c) $6\ \Omega$
 (d) $2\ \Omega$

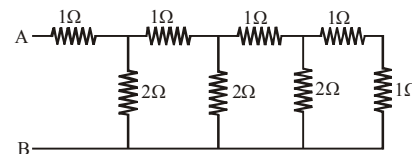

Q.3 How will reading in the ammeter

- A be affected if an other identical bulb Q is connected in parallel to P as shown in the fig. The voltage in the mains is maintained at constant value
- (a) the reading will be reduced to one half.
 (b) the reading will be double of previous one.
 (c) the reading will not be affected.
 (d) the reading will increase four fold.

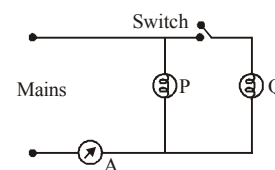

RESPONSE GRID

1. (a) (b) (c) (d) 2. (a) (b) (c) (d) 3. (a) (b) (c) (d)

Space for Rough Work

Q.4 In the circuit shown, the galvanometer G reads zero. If batteries have negligible internal resistances, the value of resistance X will be –

- (a) $10\ \Omega$
 (b) $100\ \Omega$
 (c) $200\ \Omega$
 (d) $500\ \Omega$

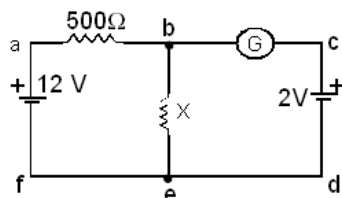

Q.5 A cylindrical wire is stretched to increase its length by 10%. The percentage increase in the resistance of the wire will be–

- (a) 20% (b) 21% (c) 22% (d) 24%

Q.6 In the figure, the equivalent resistance between A and B is–

- (a) $2R/3$
 (b) $R/3$
 (c) R
 (d) $3R$

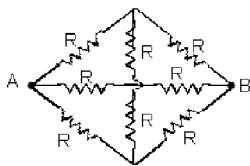

Q.7 In the adjoining network of resistors, each is of resistance r ohm, the equivalent resistance between points A and B is–

- (a) $5r$
 (b) $2r/3$
 (c) r
 (d) $r/2$

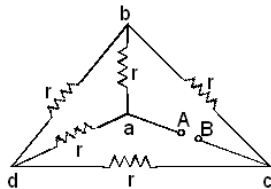

Q.8 In the figure a carbon resistor has bands of different colours on its body as mentioned in the figure. The value of the resistance is

- (a) $2.2\ \text{k}\ \Omega$
 (b) $3.3\ \text{k}\ \Omega$
 (c) $5.6\ \text{k}\ \Omega$
 (d) $9.1\ \text{k}\ \Omega$

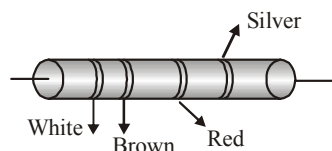

Q.9 Two wires of same material have length L and $2L$ and cross-sectional areas $4A$ and A respectively. The ratio of their specific resistance would be

- (a) 1 : 2 (b) 8 : 1 (c) 1 : 8 (d) 1 : 1

Q.10 In the fig. shown, Calculate the current through $3\ \text{ohm}$ resistor. The emf of battery is $2\ \text{volt}$ and its internal resistance is $2/3\ \text{ohm}$.

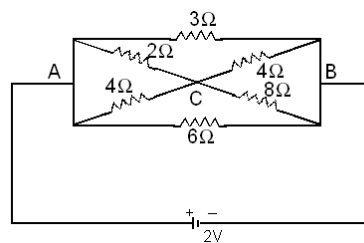

- (a) 0.33 amp. (b) 0.44 amp.
 (c) 1.22 amp. (d) 0.88 amp.

Q.11 The current in the given circuit will be

- (a) $\frac{1}{45}\ \text{A}$
 (b) $\frac{1}{15}\ \text{A}$
 (c) $\frac{1}{10}\ \text{A}$
 (d) $\frac{1}{5}\ \text{A}$

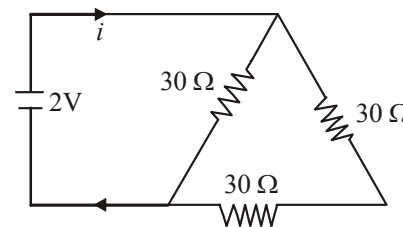

Q.12 The equivalent resistance of the following infinite network of resistance is

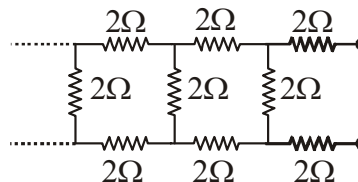

- (a) Less than $4\ \Omega$
 (b) $4\ \Omega$
 (c) More than $4\ \Omega$ but less than $12\ \Omega$
 (d) $12\ \Omega$

Q.13 A heater coil connected to a supply of $220\ \text{V}$ is dissipating some power P_1 . The coil is cut into half and the two halves are connected in parallel. The heater now dissipates a power P_2 . The ratio of power $P_1 : P_2$ is

- (a) 2 : 1 (b) 1 : 2 (c) 1 : 4 (d) 4 : 1

RESPONSE
GRID

4. (a)(b)(c)(d) 5. (a)(b)(c)(d) 6. (a)(b)(c)(d) 7. (a)(b)(c)(d) 8. (a)(b)(c)(d)
 9. (a)(b)(c)(d) 10. (a)(b)(c)(d) 11. (a)(b)(c)(d) 12. (a)(b)(c)(d) 13. (a)(b)(c)(d)

Space for Rough Work

Q.14 An electric lamp is marked 60 W, 230 V. The cost of a 1 kWh of energy is ₹ 1.25. The cost of using this lamp 8 hrs a day for 30 days is (approximately)
 (a) ₹ 10 (b) ₹ 16 (c) ₹ 18 (d) ₹ 20

DIRECTIONS (Q.15-Q.17) : In the following questions, more than one of the answers given are correct. Select the correct answers and mark it according to the following codes:

Codes :

- (a) 1, 2 and 3 are correct (b) 1 and 2 are correct
 (c) 2 and 4 are correct (d) 1 and 3 are correct

Q.15 In the fig below the bulbs are identical, The bulbs, light most brightly are

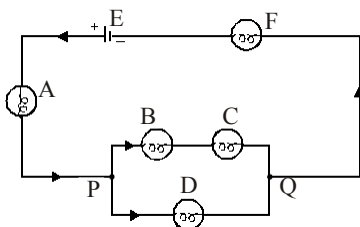

- (1) A (2) B (3) F (4) D

Q.16 An electric kettle has two heating coils. When one of the coils is switched on, the water begins to boil in 6 minutes. When the other is switched on, the boiling begins in 8 minutes. The time when the boiling begin if both coils are switched on simultaneously is (i) in series (ii) in parallel

- (1) 14 min in series (2) 3.43 min in parallel
 (3) 3.43 min in series (4) 14 min in parallel

Q.17 For the circuit shown in the figure

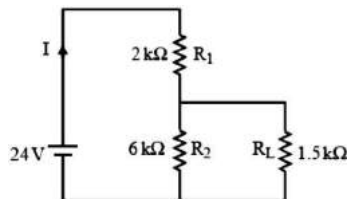

- (1) The potential difference across R_L is 18 V
 (2) The current I through the battery is 7.5 mA
 (3) Ratio of powers dissipated in R_1 and R_2 is 3
 (4) If R_1 and R_2 are interchanged magnitude of the power dissipated in R_L will decrease by a factor of 9

DIRECTIONS (Q.18-Q.20) : Read the passage given below and answer the questions that follows :

In the circuit shown in the figure,

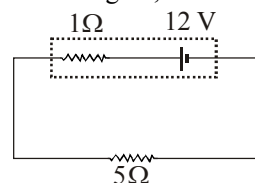

Q.18 Rate of conversion of chemical energy within the battery is

- (a) 24 W (b) 20 W (c) 4 W (d) 14 W

Q.19 Rate of dissipation of electrical energy in battery is

- (a) 24 W (b) 20 W (c) 4 W (d) 14 W

Q.20 Rate of dissipation of electrical energy in external resistor is

- (a) 4 W (b) 20 W (c) 14 W (d) 24 W

DIRECTIONS (Q. 21-Q.23) : Each of these questions contains two statements: Statement-1 (Assertion) and Statement-2 (Reason). Each of these questions has four alternative choices, only one of which is the correct answer. You have to select the correct choice.

- (a) Statement-1 is True, Statement-2 is True; Statement-2 is a correct explanation for Statement-1.
 (b) Statement-1 is True, Statement-2 is True; Statement-2 is NOT a correct explanation for Statement-1.
 (c) Statement -1 is False, Statement-2 is True.
 (d) Statement -1 is True, Statement-2 is False.

Q.21 Statement-1 : The resistivity of a semiconductor decreases with temperature.

Statement-2 : The atoms of a semiconductor vibrate with larger amplitude at higher temperatures thereby increasing its resistivity.

RESPONSE GRID

14. (a)(b)(c)(d) 15. (a)(b)(c)(d) 16. (a)(b)(c)(d) 17. (a)(b)(c)(d) 18. (a)(b)(c)(d)
 19. (a)(b)(c)(d) 20. (a)(b)(c)(d) 21. (a)(b)(c)(d)

Space for Rough Work

Q.22 Statement-1 : In a simple battery circuit the point of lowest potential is negative terminal of the battery.

Statement-2 : The current flows towards the point of the higher potential as it flows in such a circuit from the negative to the positive terminal.

Q.23 Statement-1 : The temperature coefficient of resistance is positive for metals and negative for p-type semiconductor.

Statement-2 : The effective charge carriers in metals are negatively charged whereas in p-type semiconductor they are positively charged.

RESPONSE GRID

22. (a) (b) (c) (d) 23. (a) (b) (c) (d)

DAILY PRACTICE PROBLEM SHEET 36 - PHYSICS

Total Questions	23	Total Marks	92
Attempted		Correct	
Incorrect		Net Score	
Cut-off Score	24	Qualifying Score	40
Success Gap = Net Score – Qualifying Score			
Net Score = (Correct × 4) – (Incorrect × 1)			

Space for Rough Work



DAILY PRACTICE PROBLEMS

PHYSICS SOLUTIONS

36

1. (b). The current in 1Ω resistance is 3A. The current in 3Ω resistance is

$$I_1 = \frac{R_2}{R_1 + R_2} I = \frac{6}{3+6} \times 3 = 2A.$$

Therefore the ratio is $\frac{2}{3}$.

2. (d). $R = \frac{(R_1 + R_2)}{2} + \frac{1}{2} [(R_1 + R_2)^2 + 4R_3]$
 $(R_1 + R_2)^{1/2}$ (a)
 $R_1 = 1\Omega, R_2 = 0, R_3 = 2\Omega$ (b)
 From eqs. (a) and (b)

$$R = \frac{1}{2} + \frac{1}{2} [1 + 4 \times 2 \times 1]^{1/2} = \frac{1}{2} [1 + 3] = 2\Omega.$$

3. (b). Since Q is connected in parallel the net resistance becomes $R/2$, so the current $I = 2V/R$, double the value.
 4. (b). Since there is no current in edcb part, the p.d. across be should be 2V. Let current in 500Ω is I, then same current flows through X (think). Therefore, for loop abefa,
 $12 = I(500) + IX$
 or $12 = I(500) + 2$ ($\therefore IX = 2$ volt)
 Thus $I = (1/50)$ A or from $IX = 2$,
 $X = 2 \times 50 = 100\Omega$.
 5. (b). Let ℓ_1 be the initial length of the wire. Then the new length will be

$$\ell_2 = \frac{110}{100} \ell_1 = \frac{11}{10} \ell_1$$

Since, the volume remains constant

$$A_1 \ell_1 = A_2 \ell_2 \text{ or } A_1 / A_2 = \ell_2 / \ell_1 = \frac{11}{10}$$

(where A_1 and A_2 are initial and final area of cross-section of the wire).

If R_1 and R_2 are the initial and final resistances, then

$$\frac{R_1}{R_2} = \frac{\ell_1 A_2}{\ell_2 A_1} = \frac{10}{11} \times \frac{10}{11} = \left(\frac{10}{11}\right)^2$$

$$\text{or } \frac{R_2}{R_1} = \left(\frac{11}{10}\right)^2$$

Now, percentage change in resistance is

$$\frac{\Delta R}{R_1} \times 100 = \left(\frac{R_2 - R_1}{R_1}\right) \times 100$$

$$= \left[\left(\frac{11}{10}\right)^2 - 1\right] \times 100 = 21\%$$

6. (a). The circuit is equivalent to Fig. It is a balanced wheatstone bridge between abcd, and then in parallel ($2R$) resistances. Thus ignoring resistance between bd arm. The circuit is equivalent to three ($2R$) resistances in parallel (abc, adc, aRRC).

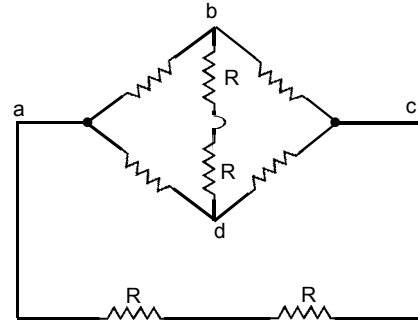

$$\text{i.e. } \frac{1}{R_{eq}} = \frac{1}{2R} + \frac{1}{2R} + \frac{1}{2R} = \frac{3}{2R}$$

$$\Rightarrow R_{eq} = \frac{2}{3} R$$

7. (c).

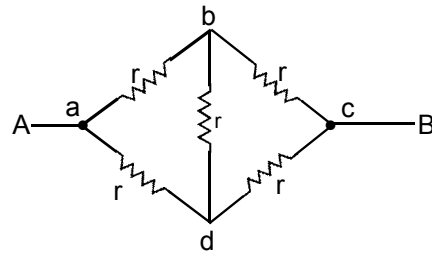

Imagine, A being pulled on the left side, then abcd becomes a balanced wheatstone bridge Fig. The arm bd can be ignored. Then resistance between A, B becomes = r .

$$\text{i.e. } \frac{1}{R_{eq}} = \frac{1}{2r} + \frac{1}{2r} = \frac{1}{r} \Rightarrow R_{eq} = r$$

8. (d) $R = 91 \times 10^2 \approx 9.1 \text{ k}\Omega$.
 9. (d) Specific resistance doesn't depend upon length and area.
 10. (b). The diagram can be redrawn as shown in fig.

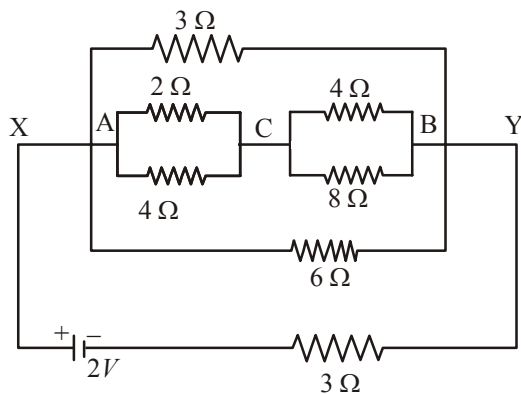

The effective resistance R_{AC} between A and C

$$\frac{1}{R_{AC}} = \frac{1}{2} + \frac{1}{4} = \frac{3}{4} \therefore R_{AC} = \frac{4}{3} \text{ ohm}$$

The effective resistance R_{CB} between C and B

$$R_{CB} = \frac{1}{4} + \frac{1}{8} = \frac{3}{8} \therefore R_{CB} = \frac{8}{3} \text{ ohm.}$$

Now, $R_{ACB} = R_{AC} + R_{CB} = \frac{4}{3} + \frac{8}{3} = 4 \text{ ohm.}$

Corresponding to points X and Y, the resistances 3 ohm, 4 ohm and 6 ohm are in parallel, hence effective resistance R_{XY} is

$$\frac{1}{R_{XY}} = \frac{1}{3} + \frac{1}{4} + \frac{1}{6} = \frac{4+3+2}{12} = \frac{9}{12}$$

$$\therefore R_{XY} = \frac{12}{9} = \frac{4}{3} \text{ ohm.}$$

Total resistance R of the circuit = $\frac{4}{3} + \frac{2}{3} = 2 \Omega$.

Current in the circuit = $\frac{2}{2} = 1 \text{ A}$

Power dissipated in the circuit = $i^2 R = 1 \times 2 = 2 \text{ watts}$
Potential difference between X and

$$Y = i \times R_{XY} = 1 \times \frac{4}{3} = \frac{4}{3} \text{ V.}$$

\therefore Potential difference across 3 ohm resistor = $\frac{4}{3} \text{ V.}$

Current in 3 ohm resistor = $\frac{4/3}{3} = \frac{4}{9} = 0.44 \text{ amp.}$

11. (c). Requivlent = $\frac{(30+30)30}{(30+30)+30} = \frac{60 \times 30}{90} = 20 \Omega$

$$\therefore i = \frac{V}{R} = \frac{2}{20} = \frac{1}{10} \text{ ampere}$$

12. (c). $R = 2 + 2 + \frac{2 \times R}{2 + R} \Rightarrow 2R + R^2 = 8 + 4R + 2R$

$$\Rightarrow R^2 - 4R - 8 = 0 \Rightarrow R = \frac{4 \pm \sqrt{16+32}}{2} = 2 \pm 2\sqrt{3}$$

R cannot be negative, hence $R = 2 + 2\sqrt{3} = 5.46 \Omega$

13. (c). $P = \frac{V^2}{R}$. If resistance of heater coil is R, then resistance of parallel combination of two halves will be $\frac{R}{4}$

$$\text{So } \frac{P_1}{P_2} = \frac{P_2}{P_1} = \frac{R/4}{R} = \frac{1}{4}$$

14. (c). Total kWh consumed = $\frac{60 \times 8 \times 301}{1000} = 14.4$

Hence cost = $14.4 \times 1.25 = ₹ 18$

15. (d). Since all bulbs are identical they have the same resistances. The current I flowing through 1 branches at A. So current in 2 and 3, as well as in 4 will be less than I. The current through 5 is also I. Thus 1 and 5 glow equally brightly and more than 2, 3 or 4.

16. (b). Let R_1 and R_2 be the resistances of the coils, V the supply voltage, Q the heat required to boil the water. Heat produced by first coil of resistance R_1 in time t_1

$$Q = \frac{V^2 t_1}{R_1} = \frac{V^2 \times 6 \times 60}{4.2 R_1} \text{ cal} \dots\dots(a)$$

Heat produced in second coil of resistance R_2 in time t_2 (= 8 min)

$$Q = \frac{V^2 t_2}{R_2} = \frac{V^2 \times 8 \times 60}{4.2 R_2} \dots\dots(b)$$

Equating (a) and (b), we get

$$\frac{6}{R_2} = \frac{8}{R_1} \text{ i.e. } \frac{R_2}{R_1} = \frac{8}{6} = \frac{4}{3}$$

$$\text{or } R_2 = \frac{4}{3} R_1 \dots\dots(c)$$

(i) When the two heating coils are in series, the effective resistance is

$$R' = R_1 + R_2 = R_1 + \frac{4}{3} R_1 = \frac{7}{3} R_1$$

with two coils in series, let the kettle take t' time to boil.

$$Q = \frac{V^2 t'}{R'} = \frac{V^2 t'}{4.2 \times \left(\frac{7}{3} R_1\right)} \dots\dots(d)$$

Comparing (a) and (d), we get $\frac{t'}{(7/3)} = 6 \times 60$

$$\text{or } t' = \frac{7}{3} \times 6 \times 60 \text{ sec} = 14 \text{ min.}$$

(ii) When the two heating coils are in parallel, the effective resistance is,

$$R'' = \frac{R_1 R_2}{R_1 + R_2} = \frac{R_1 \left(\frac{4}{3} R_1\right)}{R_1 + \left(\frac{4}{3} R_1\right)} = \frac{4}{7} R_1$$

In parallel arrangement of heating coils, let t'' be the time taken by kettle to boil, so

$$Q = \frac{V^2 t''}{JR''} = \frac{V^2 t''}{4.2 \times \left(\frac{4}{7} R_1\right)} \quad \dots(5)$$

Comparing (a) and (5), we get

$$\frac{t''}{(4/7)} = 6 \times 60 \text{ or } t'' = \frac{4}{7} \times 6 \times 60 \text{ sec} = 3.43 \text{ min.}$$

17. (c).

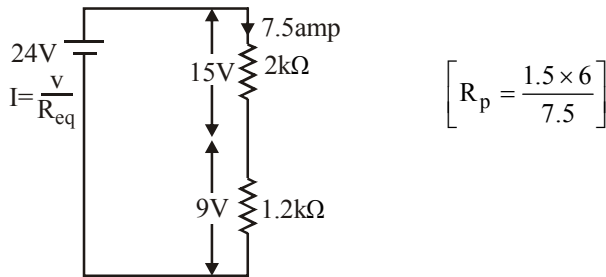

$$I = \frac{240}{32} \Rightarrow \frac{60}{8} = 7.5 \text{ mA}$$

(1) Current I is 7.5 mA

(2) Voltage drop across R_L is 9 volt

$$(3) \frac{P_1}{P_2} = \frac{v_1^2}{R_1} \frac{R_2}{v_2^2} \Rightarrow \frac{225 \times 6}{2 \times 81} = 16.66$$

(4) After interchanging the two resistor R_1 and R_2

$$I = \frac{v}{R_{eq}} = \frac{24}{(48)} \times 7 = 3.5 \text{ mA}$$

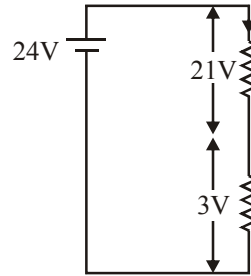

$$\frac{P_1}{P_2} = \frac{v_1^2}{R_L} \frac{R_L}{v_2^2} \Rightarrow \left(\frac{v_1}{v_2}\right)^2 = \left(\frac{9}{3}\right)^2 = 9$$

Sol. (18-20).

$$I = \frac{12V}{(1+5)\Omega} = 2A$$

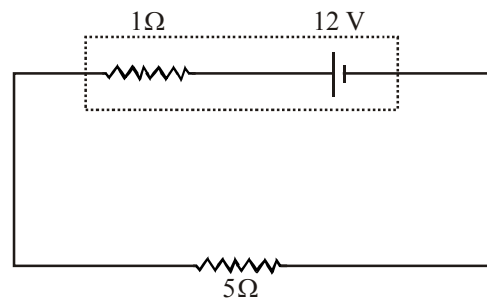

\Rightarrow Rate of chemical energy conversion $= EI = 12 \times 2 = 24 \text{ W}$
and P (in battery) $= I^2 r = 4 \text{ W}$
Also, P (in resistor) $= I^2 r = 20 \text{ W}$

18. (a) 19. (c) 20. (a)

21. (d) Resistivity of a semiconductor decreases with the temperature. The atoms of a semiconductor vibrate with larger amplitudes at higher temperatures thereby increasing its conductivity not resistivity.
22. (d) It is quite clear that in a battery circuit, the point of lowest potential is the negative terminal of the battery and the current flows from higher potential to lower potential.
23. (b) The temperature co-efficient of resistance for metal is positive and that for semiconductor is negative. In metals free electrons (negative charge) are charge carriers while in p-type semiconductors, holes (positive charge) are majority charge carriers.